

INSTALLATION INSTRUCTIONS

WOOD BLINDS

1-3/8", 2" & 2-3/8" SLAT SIZES

STANDARD RECTANGULAR

Thank you for your purchase. This blind has been custom built for you from the highest quality materials.



To avoid errors and save valuable time, please read these instructions before installing your new blind.

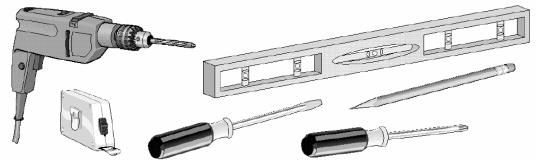

TOOLS YOU WILL NEED

1. Pencil or Marker
2. Measuring Tape
3. Flat-Head Screwdriver
4. Phillips Screwdriver
5. Carpenter's Level
6. Power Drill
7. Mounting Fasteners



Mounting Surface	Fastener
Drywall, Plaster	Wall Anchors, Expansion Bolts (Not Provided) 
Metal	Sheet Metal Screws (Not Provided) 
Wood	No. 6 Hex Head Screws (Provided) 

GETTING STARTED

All the required installation components are wrapped in your package along with these instructions. Check that the parts you have correspond to the parts shown below. **NOTE:** Some parts may vary depending upon your chosen mounting options and whether intermediate brackets are required.

PARTS

- Installation Brackets
- Center Support Brackets (blinds over 48" wide)
- 2" or 4" Extension Brackets (optional)
- Spacer Blocks (For 2-3/8" Slats)
- Valance Clips
- Hold Down Brackets (optional – 2 types)
- Bracket Shims
- Screws

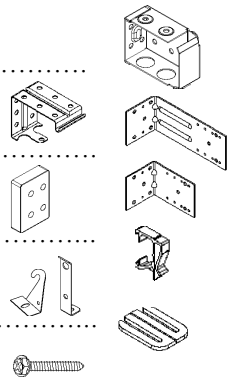

STEP 1: MOUNTING THE BRACKETS

The installation brackets may be used for **INSIDE**, **OUTSIDE** or **CEILING** mounts. The brackets are stamped R.H. (right hand) and L.H. (left hand) for easy identification.

Mounting the brackets level is essential for proper operation of the blind. Shim the brackets if necessary to achieve a level alignment.

SPACER BLOCKS (standard for 2-3/8" Slats):

- Spacer blocks will be attached to the end of each bracket.
- If installing extension brackets, do not use spacer blocks.

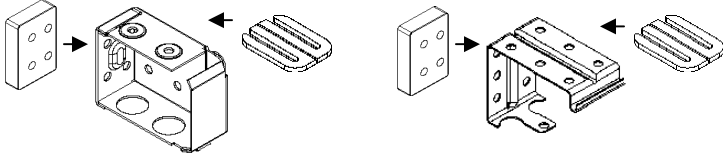

position spacer block to end of bracket, shim on top of bracket (if necessary)

Blind Width	Center Support Brackets
12" to 48"	0
48-1/8" to 60"	1
60-1/8" to 120"	2

INSIDE MOUNTS:

For inside mounts the installation brackets may be screwed in place either through the side or through the top holes of each bracket.

ATTACH THE BRACKETS:

- For better side mounting, screw through one side and one top hole.
- For limited surface depths, screw through two diagonal side holes.
- For top mounting, screw through the two top holes.

Inside mount bracket screwed through side and top holes.

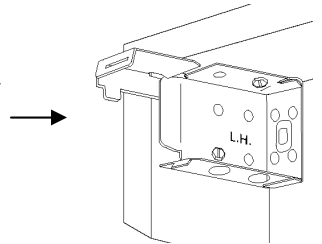

CENTER SUPPORT BRACKETS (if required):

- Space evenly between the two end brackets.
- Adjust if necessary to avoid interference with internal headrail parts.
- Attach with screws through two diagonal holes.

Inside Mount Depth Requirements

Slat Size	Bracket Depth	Flush To Valance Depth
1-3/8"	1-1/8"	3"
2"	1-1/8"	3"
2-3/8"	1-1/8"	3-1/2"

OUTSIDE MOUNTS:

For outside mounts, ensure that a 1-3/4" high, flat vertical surface is available for securing the installation brackets. The brackets will be screwed in place through the back holes.

MARK THE BRACKET POSITIONS:

- Mark where the ends of the headrail will be positioned. Either...
- Hold headrail up and mark or measure headrail and mark length.
- Then mark 1/4" from the headrail marks for the installation brackets.

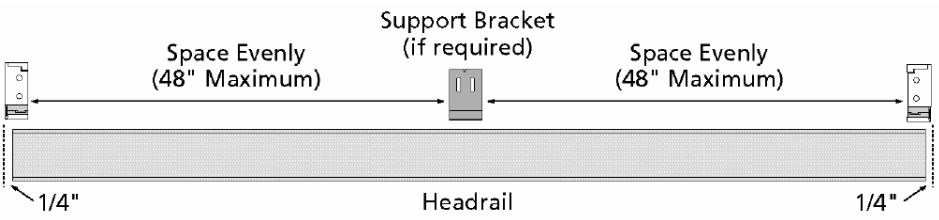

ATTACH THE BRACKETS:

- Position the outside edge of the brackets to the outer markings.
- The bracket tops must be aligned and level to one another.
- Attach the brackets with screws through two diagonal holes.

Outside mount bracket screwed diagonally through back holes.

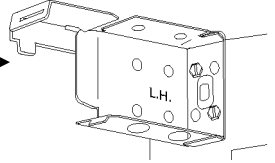

CENTER SUPPORT BRACKETS (if required):

- Space the center bracket(s) evenly between the two end brackets.
- Adjust if necessary to avoid interference with headrail mechanisms.
- Attach with screws through two diagonal holes.

EXTENSION BRACKETS (optional):

- Position the extension brackets to the wall markings made above.
- The bracket tops must be aligned and level to one another.
- Mount the extension brackets with screws through diagonal holes.
- Attach the installation brackets to the extension brackets.

Installation brackets and center support brackets attach to extension brackets with the included screws and nuts.

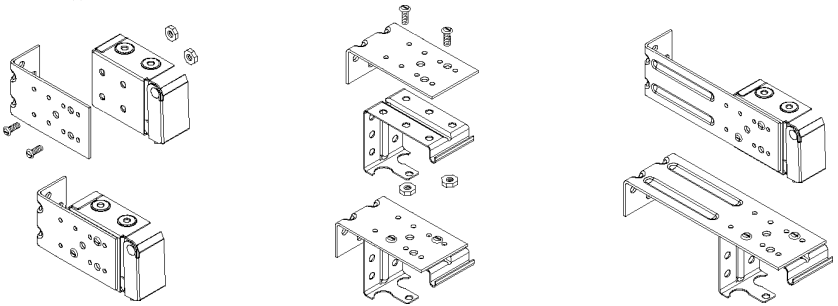

CEILING MOUNTS:

For ceiling mounts, ensure that a 1-3/4" high, flat vertical surface is available for securing the installation brackets. The brackets will normally be screwed in place through the top holes, but see optional attachments below.

MARK THE BRACKET POSITIONS:

- Mark where the ends of the headrail will be positioned. Either...
- Hold headrail up and mark or measure headrail and mark length.
- Then mark 1/4" from the headrail marks for the installation brackets.

ATTACH THE BRACKETS:

- For normal ceiling mounts, screw through the top holes.
- If brackets sides are also flat to wall, screw through top & side holes.
- If brackets backs are flat to wall, screw through top & back holes.

STEP 2: INSTALLING THE BLIND

With the installation brackets in place, the headrail may now be mounted. For inside mounts and ceiling mounts, attach the valance clips to the headrail before mounting. For outside mounts, attach the valance clips to the headrail after mounting.

ATTACH VALANCE CLIPS TO HEADRAIL:

- Valance clips will attach to the front lip of the headrail.
- Position one clip at each end of the headrail and snap in place.
- Evenly space other clips (no more than 48" apart).
- Verify that the clips align to the channels on the valance back.

OPEN THE BRACKET DOOR LATCHES:

- Press up on the bracket bottoms while lifting bracket doors open.

MOUNT THE HEADRAIL:

- Tilt the headrail slightly backward to lower the back-side lip.
- Slide the headrail into the brackets and push it all the way back.
- The front lip of the headrail should hook to the center support lips.

VERIFY HEADRAIL FIT:

- If the headrail moves left or right more than 1/8", adjust...
- Using a flat head screwdriver, bend the end stiffener tabs out.

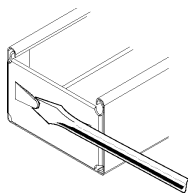

CLOSE THE BRACKET DOOR LATCHES:

- Snap the door shut over the locking tab to secure.

STEP 3: INSTALL REMAINING ITEMS

With the blind properly mounted and in place, any additional components may now be attached. These include a wand tilter (if ordered), a decorative valance and hold-down brackets (if ordered).

ATTACH THE WAND:

- Remove plastic sleeve from wand tip and slide it up the metal shaft.
- Slip exposed wand hook through the tilter stem hole.
- Push plastic sleeve back down and over the wand hook until secure.
- Operate the wand by rotating between fingers.

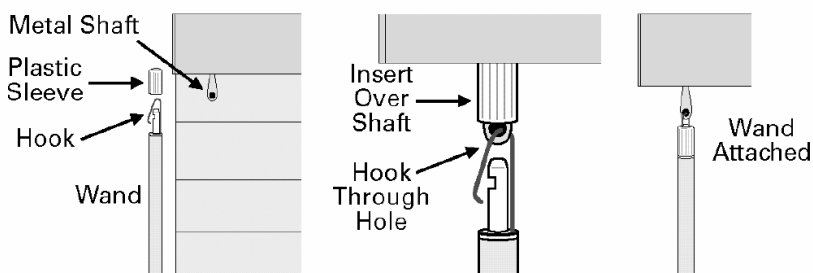

ATTACH THE VALANCE:

- If the valance clips are not attached to the headrail, do so now.
- Hold the valance up and align the back channel strips to the clips.
- Press on the valance face to lock it in place.

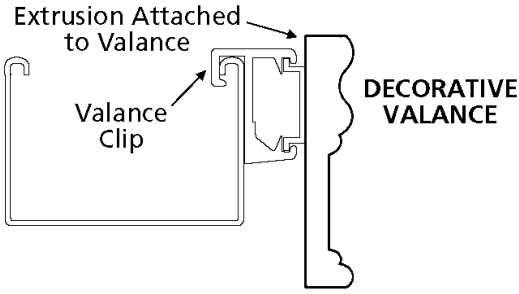

ATTACH THE HOLD DOWN BRACKETS:

- Attach hold down brackets to the window sill or an outside surface.
- Lower the blind, align bottom rail pins to the bracket hole or hook.

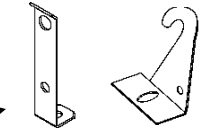

2 Hold Down Types

STEP 4: OPERATING THE BLIND

TO TILT THE SLATS:

- Pull on one of two tilt cords to rotate slats forwards or backwards.
- Rotate wand tilter to rotate slats forwards and backwards.

TO RAISE AND LOWER THE BLIND:

- Tilt the slats to the open position (flat and parallel to headrail).
- Pull the single lift cord down and toward the center of the blind.
- Raise or lower blind to desired position, then...
- Move the cord toward the outside of the blind to lock, then release.

CLEANING INSTRUCTIONS

DUSTING: Like any piece of furniture, dust your blinds regularly. Use an ordinary soft, clean cloth, chemically treated dust cloth, dusting mitt or cylindrical dust brushes especially designed for blinds. Lower the blind to its full length, tilt the slats almost fully closed and dust. Then dust the reverse side of the slats in the same manner. In order to reach the dust where the slats overlap, it is best not to fully close the blind in either position.

VACUUMING: To use your vacuum for cleaning your blind, use the brush attachment provide with your vacuum. Use the same procedure as mentioned above.

DAMP CLEANING: To wipe your blinds, use a soft cloth or sponge. Use warm or cold water - NOT hot water. Place toweling on the floor or sill and wipe the blind in sections.

IMPORTANT NOTE: Ultrasonic cleaning is NOT recommended for wood blinds.

SAFETY

CORD STOP: This component breaks apart with minimal pressure should a child or pet become entangled on the top lift cords. It also acts as a stopper to prevent inner cords from being pulled through the blind, which can also create potential entanglement.

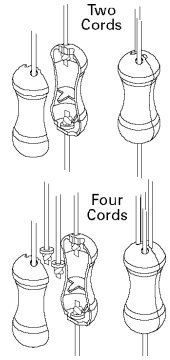

REASSEMBLY OF CORD STOP: Reinsert any loose cords into the top notches of the cord stop. There is a notch on each side. Line up the right and left sides of the cord stop and snap the pieces back together.

WARRANTY INFORMATION

Lifetime Limited Warranty covering our Custom Made Blinds

We extend this lifetime limited warranty to the original purchaser. This warranty applies only to manually operated Custom Products properly installed in the window, door or interior area for which they were intended. Installation of the product must be in accordance with accompanying instructions. The product cannot be modified. It is the purchaser's responsibility to maintain and clean the product in compliance with the instruction provided. The product must be used only in the window for which it was purchased. Damage to the product resulting from misuse, abuse, direct exposure to salty air or discoloration due to sunlight or the passage of time is not covered by this warranty.

This warranty does not apply to conditions caused by normal wear and tear upon the product. This warranty is exclusive and in lieu of all other obligations, liabilities or warranties. In no event shall the Manufacturer be liable for incidental or consequential damages or for any other direct or indirect damage, loss, cost, expense or fee. Some states do not allow the exclusion or limitation of incidental or consequential damages, so this exclusion or limitation may not apply to you.

In the event of a defect under this warranty, we will repair or replace the product, at our option, provided it is returned to our store. Our warranty obligation excludes shipping charges and labor costs for measuring and installation. Repairs will be made with like or similar parts. This warranty gives you specific legal rights, and you may have other rights which vary from state to state.

Notes: Specialty Blinds and Shades are warranted for one year from the date of purchase. This warranty does not apply to Commercial Orders.